

Design Professionals' Guide and CSI Specifications

Introduction

During the past decade, insulating concrete form (ICF) construction has accounted for an ever-increasing share of the overall construction market. Architects and designers throughout the country have found that ICFs meet their design and technical challenges easily and economically, while providing value-added structures to their customers.

The following is an overview of the iForm™ by Reward Wall Systems. iForm is acknowledged as the most technologically advanced ICF in the industry, because of its innovative design and technical features that set it apart from other ICFs. Since its introduction in the spring of 2000, easy-to-use iForm has become the ICF of choice for commercial projects ranging from small strip malls to multi-story condominiums, hotels and theaters, as well as a wide range of residential projects. In addition, Reward Wall Systems, Inc. believes so strongly in providing the best customer service possible that we have named our customer service program—Solid SupportSM. Reward provides training and technical support throughout the design and construction process to ensure that each project goes up smoothly and quickly.

iForm Advantages

iForm is a sustainable green product that saves energy and provides storm safety as well as a quiet, comfortable interior environment.

Sustainable/Green Building and LEED™

Reward ICFs allow architects and designers to create buildings that use fewer natural resources and are more sustainable. Reward ICFs:

- Reduce waste at the construction site, and any waste produced is 100% recyclable
- Use fewer natural resources, such as gas, electric and wood
- Are manufactured clean, producing no HCFCs or CFCs during the manufacturing process, and they contain no formaldehyde
- Reduce operating costs
- Create structures that last longer and with less maintenance

When Reward Wall Systems is incorporated into a LEED conforming exterior envelope, the energy efficiency and material properties of Reward can help a project qualify for points in four of the six LEED New Construction categories. The staff at Reward will be glad to assist you with questions and issues related to conformance with LEED Rating System requirements. The Pennsylvania Department of Environmental Protection building, built with Reward ICF walls, holds a bronze LEED rating, and the McGinnis Boy Scout Education Center, completed with Reward walls in 2004, earned a silver LEED rating.

Energy Efficiency

Because of their effective R-value of 32+, Reward structures can save as much as 50 % to 80% on heating and cooling costs compared to the heating and cooling costs for conventionally built structures.

Quiet and Comfort

Reward ICFs create a clean, virtually airtight, interior environment. The monolithic concrete walls, surrounded by several inches of expanded Polystyrene (EPS), serve as a barrier to drafts, pollens and other pollutants. With an excellent sound transmission rating, a Reward wall is one of the "quietest" wall systems available, reducing loud exterior noise to the level of a whisper inside.

iForm Characteristics and Uses

iForm is designed to function as the formwork for concrete walls. The formwork stays in place as insulation on the exterior and interior face of the wall assembly, and also serves as attachment for exterior and interior finish systems. It forms a solid flat steel-reinforced cast-in-place concrete wall of 4", 6", 8" or 10" thicknesses that is the structural component of the wall assembly.

iForm is used in commercial and residential construction for exterior and interior, load bearing and non-load bearing, above grade and below grade walls. Specific applications include frost walls, basement walls, storm shelters, demising walls, slab on grade walls, non-load bearing walls on post tension floor slabs, and single story to multi-story walls.

iForm is a modular pre-assembled form that is stacked together in running bond creating a concrete cavity of various thicknesses. It has two faces or panels of EPS material 2½" thick that are held together by plastic ties spaced 6" o.c.

Product literature, technical information, AutoCAD details, CSI Specifications and product samples are available upon request.

iForm Raw Materials and Manufacturing

iForm is shape molded to a nominal 1.5 pcf density using Type 2 flame retardant EPS to form two panels of insulation. A pentane gas inside the closed cell EPS resin bead is used to pre-expand the EPS resin beads. After the pre-expanded beads are injected into the mold cavity, steam and heat are applied to shape mold the product. Virtually all of the pentane gases are disbursed by the time the forms are shipped.

Plastic ties, molded from polypropylene plastic, are inserted into the mold during the shape molding process.

Complete MSDS sheets about the raw materials in iForm are available on request.

iForm Types and Sizes Available

All iForms are pre-assembled and modular. The type and size of product is determined by structural requirements, fire and sound rating requirements and designer or owner preference.

iForm Specifications

Straight	Length	Concrete Width	Return	Surface Area
9" Form	48"	4"	N/A	5.33 SF
11" Form	48"	6"	N/A	5.33 SF
13" Form	48"	8"	N/A	5.33 SF
15" Form	48"	10"	N/A	5.33 SF
Standard 90° Corner	Outside Length	Concrete Width	Return	Surface Area
9" Form	25"	4"	13"	4.22 SF
11" Form	27"	6"	15"	4.67 SF
13" Form	29"	8"	17"	5.11 SF
15" Form	31"	10"	19"	5.54 SF
Extended 90° Corner	Outside Length	Concrete Width	Return	Surface Area
9" Form	31"	4"	19"	5.55 SF
11" Form	33"	6"	21"	6.00 SF
13" Form	35"	8"	23"	6.44 SF
45° Corner	Outside Length	Concrete Width	Outside Return	Surface Area
9" Form	22"	4"	10"	3.55 SF
11" Form	22"	6"	10"	3.55 SF
13" Form	22"	8"	10"	3.55 SF
Ledge Form	Length	Concrete Width	Return	Surface Area
11" Form	48"	6" + 4 ½" Ledge	N/A	5.33 SF
13" Form	48"	8" + 4 ½" Ledge	N/A	5.33 SF
Taper Top	Length	Concrete Width	Return	Surface Area
11" Form	48"	6" + 1 ⅞" Ledge	N/A	5.33 SF
13" Form	48"	8" + 1 ⅞" Ledge	N/A	5.33 SF

iForm Concrete Use

Straight	1 Cu. Yd. Fills:	Sq. Ft. Wall Area Filled (Cu. Yd.)	Volume Per Form (Cu. Yd.)
9" Form	15.1 Forms	80.0	0.0658
11" Form	10.0 Forms	53.8	0.0988
13" Form	7.5 Forms	40.5	0.1317
15" Form	6.0 Forms	32.3	0.1646
Standard 90° Corner	1 Cu. Yd. Fills:	Sq. Ft. Wall Area Filled (Cu. Yd.)	Volume Per Form (Cu. Yd.)
9" Form	25.0 Forms	105.5	0.0400
11" Form	15.7 Forms	73.3	0.0637
13" Form	11.0 Forms	56.2	0.0909
15" Form	8.3 Forms	44.2	0.1200
Extended 90° Corner	1 Cu. Yd. Fills:	Sq. Ft. Wall Area Filled (Cu. Yd.)	Volume Per Form (Cu. Yd.)
9" Form	17.8 Forms	98.8	0.0562
11" Form	11.3 Forms	67.8	0.0885
13" Form	8.1 Forms	52.2	0.1235
45° Corner	1 Cu. Yd. Fills:	Sq. Ft. Wall Area Filled (Cu. Yd.)	Volume Per Form (Cu. Yd.)
9" Form	25.5 Forms	90.5	0.0392
11" Form	16.5 Forms	48.5	0.0606
13" Form	12.2 Forms	43.3	0.0820
Ledge Form	1 Cu. Yd. Fills:	Sq. Ft. Wall Area Filled (Cu. Yd.)	Volume Per Form (Cu. Yd.)
11" Form	7.7 Forms	41.3	0.1290
13" Form	6.1 Forms	32.9	0.1619
Taper Top	1 Cu. Yd. Fills:	Sq. Ft. Wall Area Filled (Cu. Yd.)	Volume Per Form (Cu. Yd.)
11" Form	9.1 Forms	48.5	0.01099
13" Form	7.0 Forms	37.3	0.1429

iForm Design Features

The factory formed iForm straight and corner forms are designed as universal blocks with no top or bottom, and no male or female ends. The universal design and the strong, beveled interlocking open tooth design make for quick, easy stacking and successful concrete placement.

The plastic tie inserts, spaced 6" on center, provide additional form strength during concrete placement. The ties provide loose fit and two-deep snap-in horizontal rebar chairs at several locations within the form. The loose fit eliminates the strain of bent rebar on the wall while the two deep snap-in chairs allow for rebar overlap without tying.

The 1¼" wide plastic ties are recessed ½" below the EPS surface and run the full height of the block to form continuous vertical furring strips every 6". The furring strips are marked on the exterior and interior face of the form making it easy to correctly attach exterior and interior finishes. Because the ties are recessed, traditional and acrylic finishes can be applied directly to the forms. The corner forms contain plastic corner ties to receive the exterior and interior finishes.

Within the block, the plastic ties form two tie rods that allow the iForm to be cut in half horizontally creating two blocks in one. The tie rods are spaced every 8 inches vertically. Because the 16" high blocks are the same on the top and bottom, they can be ripped every 8" and both halves can be used without wasting any product. The two-tie rod design also provides a very open cavity to allow for good concrete flow.

The tie rods provide multiple rebar positioning to allow for the most efficient structural design. The concrete wall may be designed with one or two mats of horizontal or vertical rebar. Vertical rebar should be designed in increments of 6" o.c. Horizontal rebar should be designed in increments of 16"; however, if necessary it can be designed in increments of 8".

iForm Code And Standard Conformance

iForm has been evaluated for compliance by the following code agencies for the following building codes.

- International Code Council Evaluation Service, ICC ES report for compliance to the 2003 International Building Code with 2004 Accumulative Supplement, the 2003 International Residential Code with 2004 Accumulative Supplement, the 1999 BOCA/National Building Code, the 1999 Standard Building Code, the 1999 Uniform Building Code, the 1988 International One and Two Family Dwelling Code and the SBCCI Standard for Hurricane Resistant Residential Construction SSTD-99.
- State of Wisconsin report 200246-I
- City of New York report MEA 116-03-M
- City of Los Angeles report RR 25418
- Miami-Dade County report 03.1112.05
- Florida Product Approval FL 1743
- Canadian Construction Materials Centre (CCMC) report 13107-R
- Ontario Minister's Ruling No. 04-20-124 (13107-R)

The International Residential Code also has adopted ICF construction in Sections R404.4 and R611.

The EPS insulation material is listed as an approved material by a third party agency and tested to meet the required surface burning characteristics of ASTM E84 and physical properties of ASTM c578 and CAN/ULC-S701-97.

The structural wall design is required to be in accordance with the current ACI 318 revision. Reward provides prescriptive design tables for above grade walls, below grade walls and lintels in our comprehensive *Reward Wall Systems Product Manual*.

iForm Performance Values

iForm	15"	13"	11"	9"
R-value	22	22	22	22
Thermal Mass	125	100	75	50
Air Infiltration	.04-.09 ACH	.04-.09 ACH	.04-.09 ACH	.04-.09 ACH
Fire Ratings (Design listings by Omega Point Laboratories)	4 hr.	4 hr.	3 hr.	1 or 2 hr.
Sound Transmission	TBD	TBD	48 – 65	41 – 65

iForm Vertical Courses And Stories

iForm is used for both single story and multi-story walls. The load bearing capacity for iForm walls is typically 4 to 6 stories, but iForm has been used as infill non-load bearing walls in multi-story buildings, and it can be engineered to go even higher.

Different wall thicknesses or block sizes can be designed to transition between subsequent floor levels. A 2" step must be incorporated into the design when transitioning between block sizes from floor to floor. The 2" step is typically hidden within the floor system.

The iForm is 16" high. Therefore the most convenient course increment or wall height is 16". Each iForm block can be ripped in half to provide two 8" high blocks. The 8" height is marked on both sides of the product with a raised EPS bead line. When ripped, both halves of the block can be utilized, eliminating waste. The 8" half block is typically placed on the bottom or top course so that the interlocking teeth connect. The plastic tie insert is designed so that a plastic tie remains in each half block.

Standard Course or Wall Heights (16" Course Increments)

Course	Wall Height	Course	Wall Height
1	1' 4"	7	9' 4"
2	2' 8"	8	10' 8"
3	4' 0"	9	12' 0"
4	5' 4"	10	13' 4"
5	6' 8"	11	14' 8"
6	8' 0"	12	16' 0"

Ripped Course or Wall Heights (8" Course Increments)

Course	Wall Height	Course	Wall Height	Course	Wall Height	Course	Wall Height
1	0' 8"	7	4' 8"	13	8' 8"	19	12' 8"
2	1' 4"	8	5' 4"	14	9' 4"	20	13' 4"
3	2' 0"	9	6' 0"	15	10' 0"	21	14' 0"
4	2' 8"	10	6' 8"	16	10' 8"	22	14' 8"
5	3' 4"	11	7' 4"	17	11' 4"	23	15' 4"
6	4' 0"	12	8' 0"	18	12' 0"	24	16' 0"

iForm Wall Layout And Dimensioning

The biggest difference between ICF construction and wood or metal frame construction is that the ICF wall assemblies are typically thicker. The thicker walls must be accounted for in the design phase.

The wall thickness becomes an issue when you want to keep the interior dimensions the same as in a comparable frame plan. The overall exterior dimensions are increased to keep the same interior dimensions or square footage of the building. Usually the interior walls are framed, but the increased ICF wall thickness must be accounted for in the case of demising interior walls.

Generally it is not necessary to design to any specific dimensions. However, modular design guidelines feature standard dimensions that, if used, will reduce construction costs due to reducing labor and minimizing waste. Reward usually does not recommend making compromises to the design to accommodate the block dimensions. Design the building using normal design practices, allowing the block to be adjusted to accommodate the design. In some cases it may make sense to incorporate a modular building layout to make the most efficient use of the modular iForm product. (See Appendix A.)

The iForm interlocking teeth are designed to interlock perfectly when the wall length is a multiple of 2". If the wall length is not a multiple of 2", it still can be easily constructed by using a common splice.

Designs that utilize 90° and 45° corners are the most efficient since iForm features pre-assembled 90° and 45° corner blocks. Corners of any other angle also can be constructed by mitering straight blocks in the field. Walls with nearly any radius can be built using straight forms as easily as other types of construction.

Any bump-outs and bay-outs easily can be achieved with the 90° and 45° pre-assembled corners. The most efficient designs will incorporate bump-outs using the modular layout dimensions described in Appendix A.

For cantilever and inset walls the most straightforward approach is to ensure that upper floor levels follow the wall layout of the lower stories. If this is not desirable or possible, structural engineering will be required.

Doors and Windows

iForm accommodates any height of doors or windows. Reward recommends placing the tops of doors and windows at the top of a course height, to save both labor and materials by eliminating the necessity of cutting the blocks.

Door and window jambs may be placed as close to a corner as needed as long as the wall is structurally adequate. It is necessary to allow enough wall space for finish work and proper functioning of the door or window. The spacing between two or more doors or windows is determined by the need for the structural design to allow for adequate steel reinforcement placement and to have enough wall space for finish work.

Windows are usually installed flush to the exterior face of the wall, but they also may be recessed inward to have the jambs flush to the inside. The choice is between a deep inside windowsill or a deep recess outside.

When the window is set to the outside, providing a deep inside windowsill, normal flashing and exterior treatment is required. On the interior, drywall is typically wrapped onto the sill, jambs and head. If wood trim is desired, the jambs are quite deep and require more trim material than normal. This is accomplished with jamb and sill extensions.

The hinge side of the door must be considered due to the thicker wall. Exterior hinged doors that are hung to the Reward wall should be installed so that the hinge is flush with the inside wall. This allows the door to open fully without hitting the doorjamb. Doors should be specified with jamb extensions to reflect the thicker wall plus the exterior and interior cladding.

Floor Systems

Wood frame floors are connected to the side of the wall system by rim joists or ledger boards. The floor joists, or trusses either are hung from joist hangers fastened to the ledger or bear on the ledger. The ledger can be installed at any height of the wall.

Structural concrete floor systems such as pre-cast hollow core planks, composite concrete floors or post-tension slabs also may be designed. In order to provide efficient construction and to minimize bracing, it is recommended Reward recommends that you consider the 16" or 8" form height with respect to floor elevation and floor thicknesses.

Electrical, Mechanical And Plumbing

Since the Reward wall ultimately becomes a solid concrete wall, the electrical, mechanical and plumbing penetrations through the wall must be carefully pre-planned. Penetrations are easily accommodated before the concrete is placed by installing sleeves through the wall. Examples of items that would need penetrations include exterior lighting, dryer vents, water faucets, service entrances and the main utility box.

Electrical

Electrical boxes and wiring are installed after the concrete is placed by using an electric hot knife to route channels into 2 ½" thick EPS foam. Run horizontal wires between the horizontal seams of the blocks whenever possible to avoid cutting into the plastic ties.

Plumbing and Ductwork

Plumbing should be pre-planned so that the plumbing lines are run on interior walls. If it is necessary to run any plumbing lines into the Reward wall, they easily can be routed into the 2 ½"- thick foam by creating chases with an electrical hot knife. In some cases it may make sense to fur out a wall section.

To simplify installation, Reward recommends pre-planning the ductwork so that it runs along the interior walls. When it is necessary to run any ductwork on exterior walls the wall must be furred out.

Exterior Finishes

Any typical exterior finish, such as any type of siding, traditional stucco, textured acrylic stucco and brick or stone veneer may be used with Reward walls. Siding is fastened to the plastic ties using coarse thread corrosion-resistant screws. Metal lath is fastened to the plastic ties when using traditional stucco. Textured acrylic finish is applied directly to the forms. The Reward ledge form reinforced with the Reward xLerator™ supports brick and stone veneer. Brick ties are typically fastened to the plastic ties.

Interior Finishes

All interior walls must have a 15-minute thermal barrier in compliance with ASTM E-119. Typically this is ½" drywall. Permeable paint, paper and plaster finishes are recommended. Impermeable finishes are **not** recommended.

iForm Design Awareness Considerations

Because of the differences between ICF construction and standard frame construction, certain issues must be taken into consideration when designing and building with iForm.

Building Codes

When using the product on buildings of Type I, II, III or IV construction or noncombustible type construction, please refer to the ICC ES ESR 1552 evaluation report.

Building officials may require special inspections for placement of concrete and steel reinforcement according to the local building code.

Thermal Barrier

The Reward walls, including basement and garage walls, must be separated from the interior of the building with an approved 15-minute thermal barrier. An exception is made for crawl space construction when entry is limited to service of utilities, it doesn't connect to basement areas, it is properly ventilated and the air is not circulated to other parts of the building.

Sizing HVAC

Building with Reward walls creates a very energy efficient exterior building envelope. The exterior walls have a high R-value, thermal mass and very low air infiltration that must all be considered in sizing the mechanical HVAC system. It is very important to right size the HVAC system to maximize the energy efficiency and to properly remove indoor moisture. The Portland Cement Association (PCA) offers HVAC sizing software for concrete homes. It can be ordered for \$60 at 847-966-6200.

Protection From UV Rays

iForm is made from EPS foam and plastic, which is subject to UV degradation. Reward recommends that the forms be covered for protection from UV rays if they are to be stored outside for an extended period of time. Also if there is a large time lag between stacking the forms and placing the concrete, the top course should be covered to protect the plastic ties.

The only time UV degradation becomes an issue is when an exterior or interior material is to be directly adhered to the EPS. In that case Reward recommends rasping the degradation from the surface of the wall. UV degradation does not affect the performance of the wall system.

Wall Construction

The structural floor diaphragm must be in place or the walls must be adequately braced prior to backfilling. Vertical alignment and bracing is recommended every 6'-0" when stacking and placing concrete.

Cover the top interlocking teeth with tape when you are planning to place concrete on a subsequent pour. This will eliminate concrete from getting in the teeth and affecting the interlocking of the subsequent course.

When you are using brick ties to tie brick veneer to the exterior face of the building in high seismic or wind design areas, it may be necessary to fasten the brick tie to the concrete in lieu of the plastic ties.

Waterproofing and Termite Protection

Reward walls require proper waterproofing below grade using material compatible with EPS. The ICF-Compatible Construction Products section of the *Reward Product Manual* lists several products that work well as waterproofing membranes. A drainage mat or protection mat is usually recommended between the waterproofing membrane and the backfill. Brush-on, spray-on or trowel-on membranes are not recommended. Other standard waterproofing techniques such as proper flashing, drainage, grading and sealing are required.

In areas vulnerable to termite infestation, Reward recommends using Polyguard 650XTP waterproofing membrane below grade. This product has been approved as termite protection and waterproofing on ICF walls by SBCCI PST & ES. Waterproofing and treating for termites are as manageable or more manageable with ICF construction as they are with frame construction.

Attachment

When planning to hang heavy cabinets or fixtures from the Reward wall, backing should be installed either before or after the concrete is placed. The backing should be fastened to the concrete wall using concrete fasteners and installed so that it is flush with the surface of the EPS foam face. A hot knife is used to remove the EPS foam and create the space for the backing.

A product called the Grappler is available as a backing for curtain rods, towel bars or tissue holders. The Grappler is a perforated steel plate that is pressed into the EPS foam where the items being hung from the wall are located. After the drywall is installed, the Grappler plates can be located with a stud finder, and the items can be attached in the conventional way.

APPENDIX A

Architectural Dimensions For 9" iForm Extended 90-Degree Corner

iForm Thickness: 9 in.
 Short Leg Dimension = 19 in.
 Long Leg Dimension = 31 in.

Outside Dimension	Inside Dimension	Inside Corner to Outside Corner Dimension
4' 2"	2' 8"	3' 5"
8' 2"	6' 8"	7' 5"
12' 2"	10' 8"	11' 5"
16' 2"	14' 8"	15' 5"
20' 2"	18' 8"	19' 5"
24' 2"	22' 8"	23' 5"
28' 2"	26' 8"	27' 5"
32' 2"	30' 8"	31' 5"
36' 2"	34' 8"	35' 5"
40' 2"	38' 8"	39' 5"
44' 2"	42' 8"	43' 5"
48' 2"	46' 8"	47' 5"
52' 2"	50' 8"	51' 5"
56' 2"	54' 8"	55' 5"
60' 2"	58' 8"	59' 5"
64' 2"	62' 8"	63' 5"
68' 2"	66' 8"	67' 5"
72' 2"	70' 8"	71' 5"
76' 2"	74' 8"	75' 5"
80' 2"	78' 8"	79' 5"
84' 2"	82' 8"	83' 5"
88' 2"	86' 8"	87' 5"
92' 2"	90' 8"	91' 5"
96' 2"	94' 8"	95' 5"
100' 2"	98' 8"	99' 5"
104' 2"	102' 8"	103' 5"

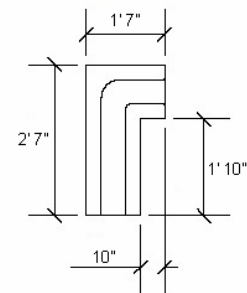
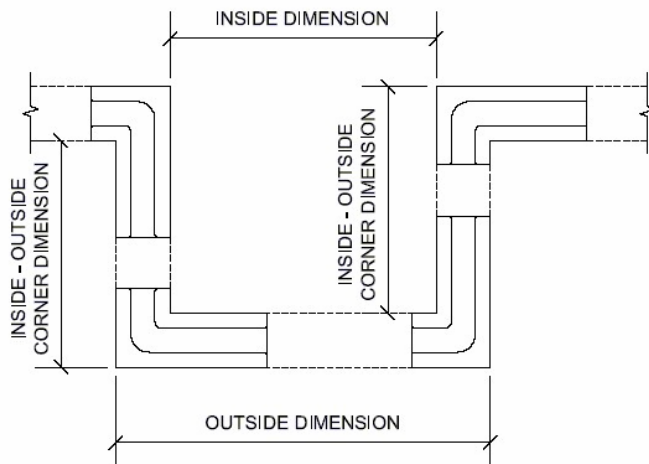

Architectural Dimensions For 11" iForm Extended 90-Degree Corner

iForm Thickness: 11 in.
 Short Leg Dimension = 21 in.
 Long Leg Dimension = 33 in.

Outside Dimension	Inside Dimension	Inside Corner to Outside Corner Dimension
4' 6"	2' 8"	3' 7"
8' 6"	6' 8"	7' 7"
12' 6"	10' 8"	11' 7"
16' 6"	14' 8"	15' 7"
20' 6"	18' 8"	19' 7"
24' 6"	22' 8"	23' 7"
28' 6"	26' 8"	27' 7"
32' 6"	30' 8"	31' 7"
36' 6"	34' 8"	35' 7"
40' 6"	38' 8"	39' 7"
44' 6"	42' 8"	43' 7"
48' 6"	46' 8"	47' 7"
52' 6"	50' 8"	51' 7"
56' 6"	54' 8"	55' 7"
60' 6"	58' 8"	59' 7"
64' 6"	62' 8"	63' 7"
68' 6"	66' 8"	67' 7"
72' 6"	70' 8"	71' 7"
76' 6"	74' 8"	75' 7"
80' 6"	78' 8"	79' 7"
84' 6"	82' 8"	83' 7"
88' 6"	86' 8"	87' 7"
92' 6"	90' 8"	91' 7"
96' 6"	94' 8"	95' 7"
100' 6"	98' 8"	99' 7"
104' 6"	102' 8"	103' 7"

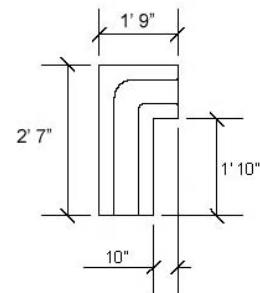
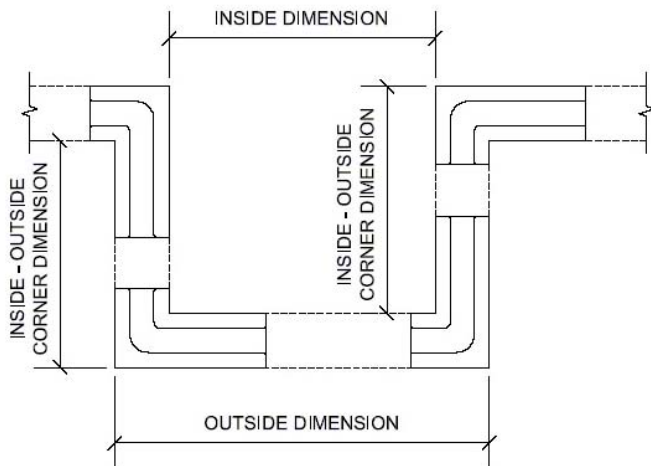

Architectural Dimensions For 13" iForm Extended 90-Degree Corner

iForm Thickness: 13 in.
 Short Leg Dimension = 17 in.
 Long Leg Dimension = 35 in.

Outside Dimension	Inside Dimension	Inside Corner to Outside Corner Dimension
4' 10"	2' 8"	3' 9"
8' 10"	6' 8"	7' 9"
12' 10"	10' 8"	11' 9"
16' 10"	14' 8"	15' 9"
20' 10"	18' 8"	19' 9"
24' 10"	22' 8"	23' 9"
28' 10"	26' 8"	27' 9"
32' 10"	30' 8"	31' 9"
36' 10"	34' 8"	35' 9"
40' 10"	38' 8"	39' 9"
44' 10"	42' 8"	43' 9"
48' 10"	46' 8"	47' 9"
52' 10"	50' 8"	51' 9"
56' 10"	54' 8"	55' 9"
60' 10"	58' 8"	59' 9"
64' 10"	62' 8"	63' 9"
68' 10"	66' 8"	67' 9"
72' 10"	70' 8"	71' 9"
76' 10"	74' 8"	75' 9"
80' 10"	78' 8"	79' 9"
84' 10"	82' 8"	83' 9"
88' 10"	86' 8"	87' 9"
92' 10"	90' 8"	91' 9"
96' 10"	94' 8"	95' 9"
100' 10"	98' 8"	99' 9"
104' 10"	102' 8"	103' 9"

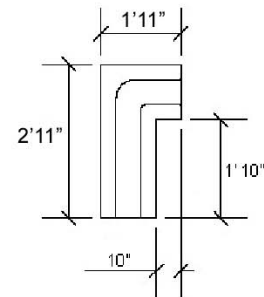
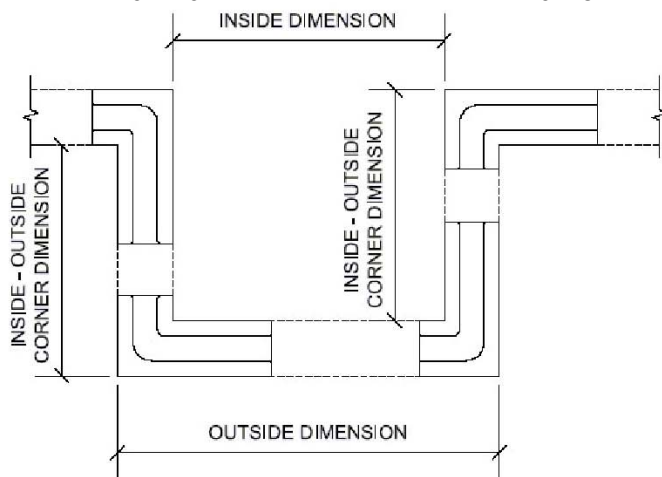

Architectural Dimensions for 9" Standard 90-Degree Corner

iForm Thickness : 9 in.
 Short Leg Dimension = 13 in.
 Long Leg Dimension = 25 in.

Outside Dimension	Inside Dimension	Inside Corner to Outside Corner Dimension
3' 2"	1' 8"	2' 5"
7' 2"	5' 8"	6' 5"
11' 2"	9' 8"	10' 5"
15' 2"	13' 8"	14' 5"
19' 2"	17' 8"	18' 5"
23' 2"	21' 8"	22' 5"
27' 2"	25' 8"	26' 5"
31' 2"	29' 8"	30' 5"
35' 2"	33' 8"	34' 5"
39' 2"	37' 8"	38' 5"
43' 2"	41' 8"	42' 5"
47' 2"	45' 8"	46' 5"
51' 2"	49' 8"	50' 5"
55' 2"	53' 8"	54' 5"
59' 2"	57' 8"	58' 5"
63' 2"	61' 8"	62' 5"
67' 2"	65' 8"	66' 5"
71' 2"	69' 8"	70' 5"
75' 2"	73' 8"	74' 5"
79' 2"	77' 8"	78' 5"
83' 2"	81' 8"	82' 5"
87' 2"	85' 8"	86' 5"
91' 2"	89' 8"	90' 5"
95' 2"	93' 8"	94' 5"
99' 2"	97' 8"	98' 5"
103' 2"	101' 8"	102' 5"

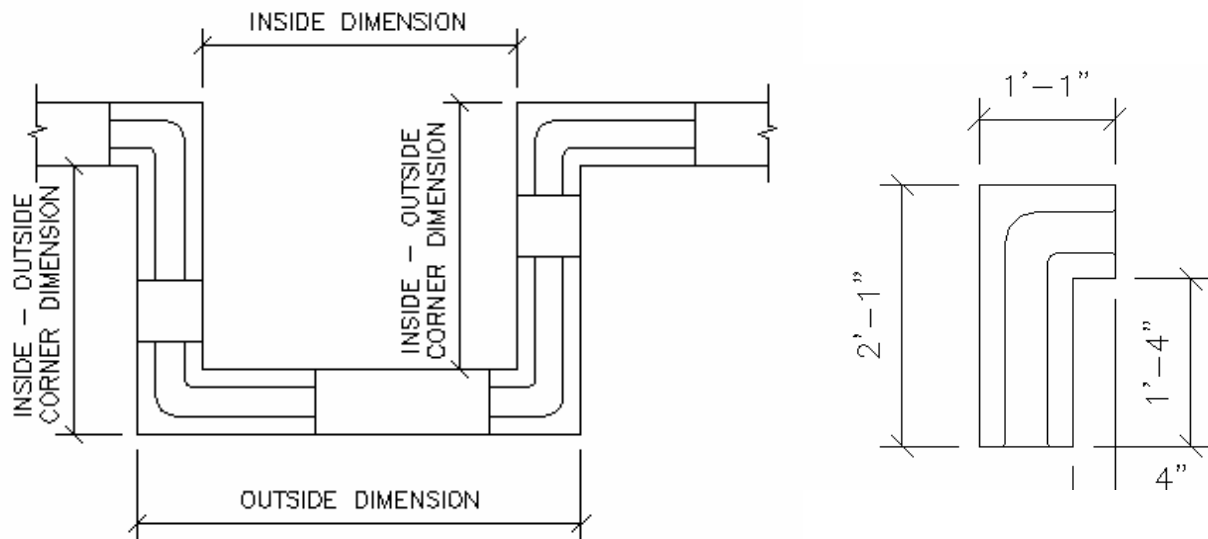

Architectural Dimensions for 11" Standard 90-Degree Corner

Form thickness 11 in.
 Short Dimension 15 in.
 Long Dimension 27 in.

Outside Dimension	Inside Dimension	Inside Corner to Outside Corner Dimension
3' 6"	1' 8"	2' 7"
7' 6"	5' 8"	6' 7"
11' 6"	9' 8"	10' 7"
15' 6"	13' 8"	14' 7"
19' 6"	17' 8"	18' 7"
23' 6"	21' 8"	22' 7"
27' 6"	25' 8"	26' 7"
31' 6"	29' 8"	30' 7"
35' 6"	33' 8"	34' 7"
39' 6"	37' 8"	38' 7"
43' 6"	41' 8"	42' 7"
47' 6"	45' 8"	46' 7"
51' 6"	49' 8"	50' 7"
55' 6"	53' 8"	54' 7"
59' 6"	57' 8"	58' 7"
63' 6"	61' 8"	62' 7"
67' 6"	65' 8"	66' 7"
71' 6"	69' 8"	70' 7"
75' 6"	73' 8"	74' 7"
79' 6"	77' 8"	78' 7"
83' 6"	81' 8"	82' 7"
87' 6"	85' 8"	86' 7"
91' 6"	89' 8"	90' 7"
95' 6"	93' 8"	94' 7"
99' 6"	97' 8"	98' 7"
103' 6"	101' 8"	102' 7"

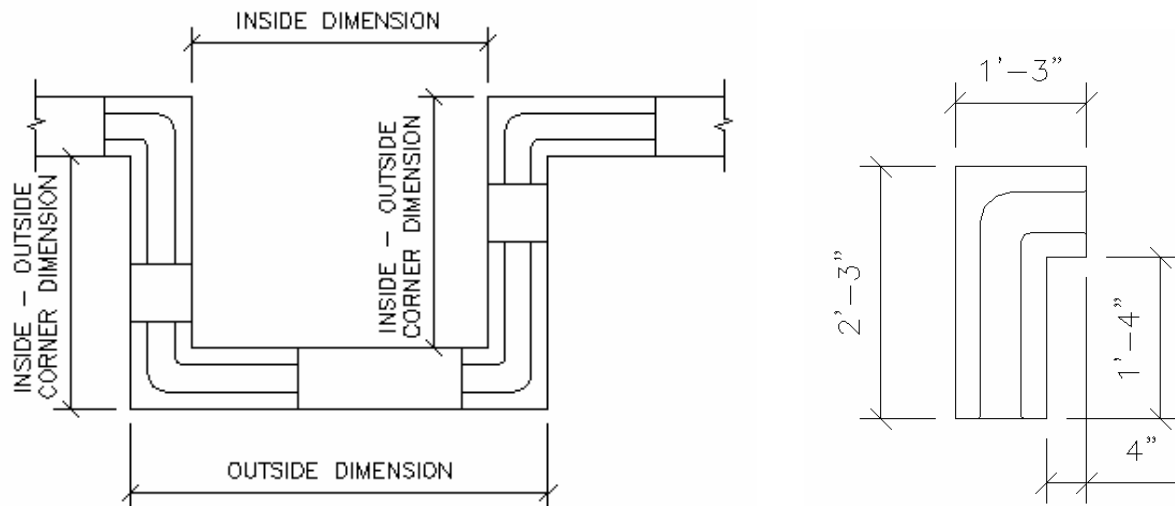

Architectural Dimensions for 13" Standard 90-Degree Corner

Form thickness 13 in.
 Short Dimension 17 in.
 Long Dimension 29 in.

Outside Dimension	Inside Dimension	Inside Corner to Outside Corner Dimension
3' 10"	1' 8"	2' 9"
7' 10"	5' 8"	6' 9"
11' 10"	9' 8"	10' 9"
15' 10"	13' 8"	14' 9"
19' 10"	17' 8"	18' 9"
23' 10"	21' 8"	22' 9"
27' 10"	25' 8"	26' 9"
31' 10"	29' 8"	30' 9"
35' 10"	33' 8"	34' 9"
39' 10"	37' 8"	38' 9"
43' 10"	41' 8"	42' 9"
47' 10"	45' 8"	46' 9"
51' 10"	49' 8"	50' 9"
55' 10"	53' 8"	54' 9"
59' 10"	57' 8"	58' 9"
63' 10"	61' 8"	62' 9"
67' 10"	65' 8"	66' 9"
71' 10"	69' 8"	70' 9"
75' 10"	73' 8"	74' 9"
79' 10"	77' 8"	78' 9"
83' 10"	81' 8"	82' 9"
87' 10"	85' 8"	86' 9"
91' 10"	89' 8"	90' 9"
95' 10"	93' 8"	94' 9"
99' 10"	97' 8"	98' 9"
103' 10"	101' 8"	102' 9"

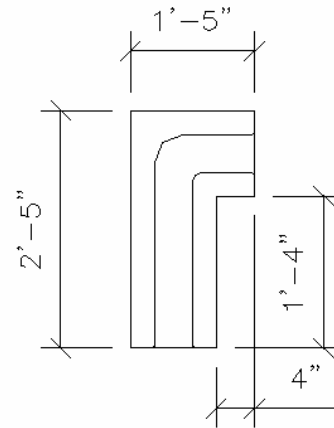
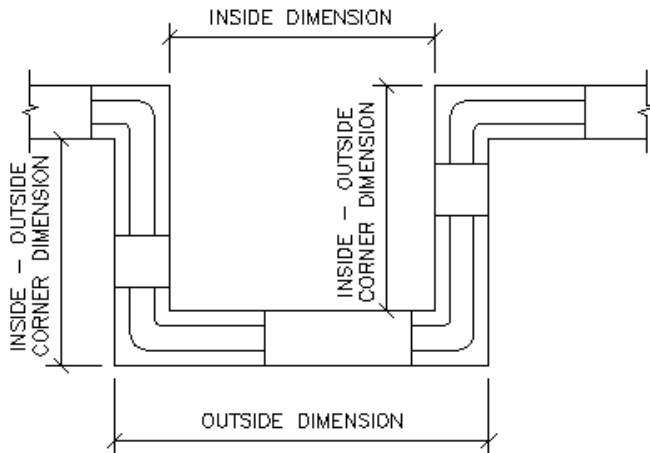

Architectural Dimensions for 15" Standard 90-Degree Corner

iForm Thickness : 15 in.
 Short Leg Dimension = 19 in.
 Long Leg Dimension = 31 in.

Outside Dimension	Inside Dimension	Inside Corner to Outside Corner Dimension
4' 2"	1' 8"	2' 11"
8' 2"	5' 8"	6' 11"
12' 2"	9' 8"	10' 11"
16' 2"	13' 8"	14' 11"
20' 2"	17' 8"	18' 11"
24' 2"	21' 8"	22' 11"
28' 2"	25' 8"	26' 11"
32' 2"	29' 8"	30' 11"
36' 2"	33' 8"	34' 11"
40' 2"	37' 8"	38' 11"
44' 2"	41' 8"	42' 11"
48' 2"	45' 8"	46' 11"
52' 2"	49' 8"	50' 11"
56' 2"	53' 8"	54' 11"
60' 2"	57' 8"	58' 11"
64' 2"	61' 8"	62' 11"
68' 2"	65' 8"	66' 11"
72' 2"	69' 8"	70' 11"
76' 2"	73' 8"	74' 11"
80' 2"	77' 8"	78' 11"
84' 2"	81' 8"	82' 11"
88' 2"	85' 8"	86' 11"
92' 2"	89' 8"	90' 11"
96' 2"	93' 8"	94' 11"
100' 2"	97' 8"	98' 11"
104' 2"	101' 8"	102' 11"

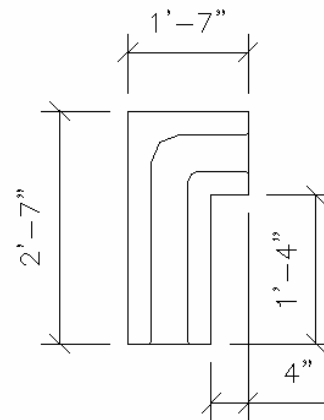
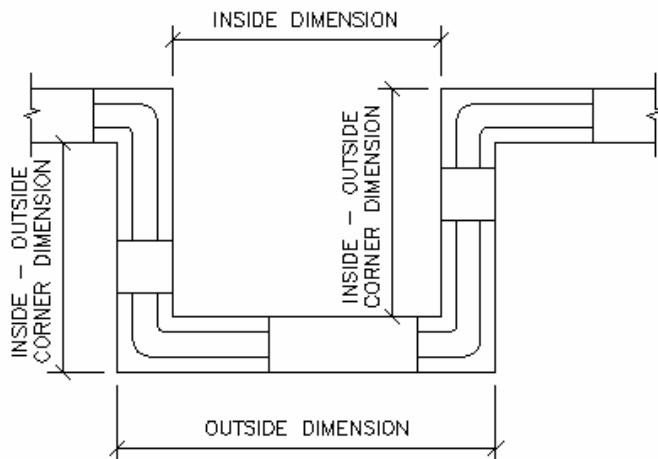

Architectural Dimensions for 9" 45-Degree Corner

iForm:	9 in.
Long Leg Dimension =	22 in.
Short Leg Dimension =	10 in.
A =	18.272 in.
B =	4.435 in.
C =	6.272 in.
D =	7.071 in.
E =	15.556 in.
F =	12.920 in.

Exterior Bay Face X (in.)	Interior Bay Face Y (in.)	Bay Projection Z (in.)
32	24.544	19.991
80	72.544	53.933
128	120.544	87.874
176	168.544	121.815
224	216.544	155.756

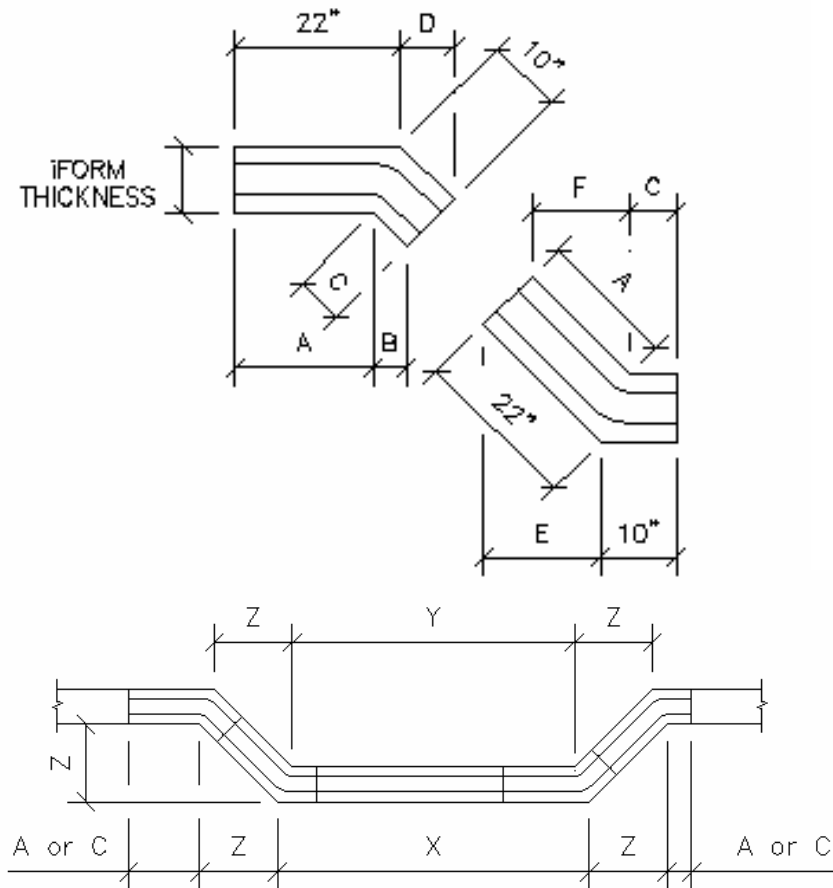

Architectural Dimensions for 11" 45-Degree Corner

iForm:	11 in.
Long Leg Dimension =	22 in.
Short Leg Dimension =	10 in.
A =	17.444 in.
B =	3.849 in.
C =	5.444 in.
D =	7.071 in.
E =	15.556 in.
F =	12.335 in.

Exterior Bay Face X (in.)	Interior Bay Face Y (in.)	Bay Projection Z (in.)
32	22.887	19.406
80	70.887	53.347
128	118.887	87.288
176	166.887	121.229
224	214.887	155.170

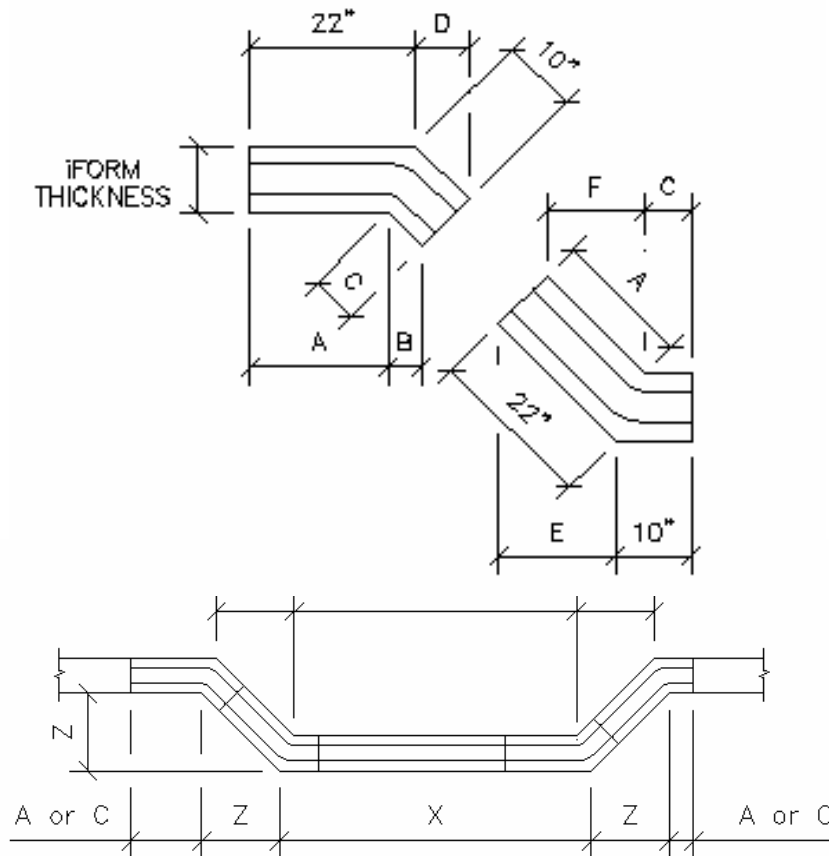

Architectural Dimensions for 13" 45-Degree Corner

iForm:	13 in.
Long Leg Dimension =	22 in.
Short Leg Dimension =	10 in.
A =	16.615 in.
B =	3.263 in.
C =	4.615 in.
D =	7.071 in.
E =	15.556 in.
F =	11.749 in.

Exterior Bay Face X (in.)	Interior Bay Face Y (in.)	Bay Projection Z (in.)
32	21.230	18.820
80	69.230	52.761
128	117.230	86.702
176	165.230	120.643
224	213.230	154.584

